

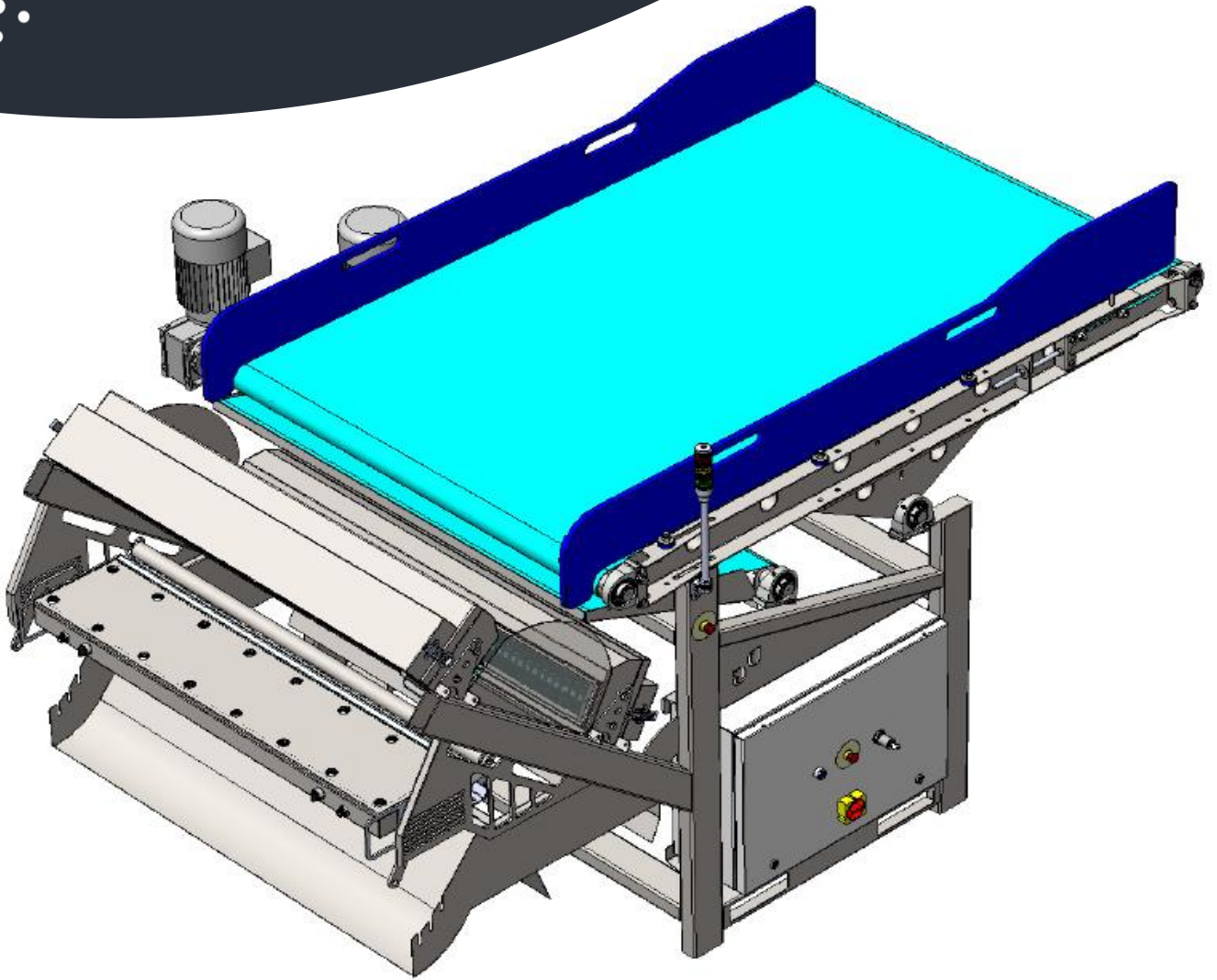

OPTICROP



# THE COST EFFECTIVE TOMATOES SORTER

Capacity up to

**85 T/h**

**72" Wide**

with sensor based  
double vision



With a double-vision sensor based sorter, equipped with Visible Color and NIR technology (Near Infra Red) the system can detect organic or inorganic foreign bodies, rotten products and color defects.

Thanks to the 72 channels configuration, the capacity for a large and industrial production is guaranteed up to 85 t/h.

The ejection system is made by mechanical fingers pneumatic actuated, manufactured in a special high-resistance and anti-abrasion material.

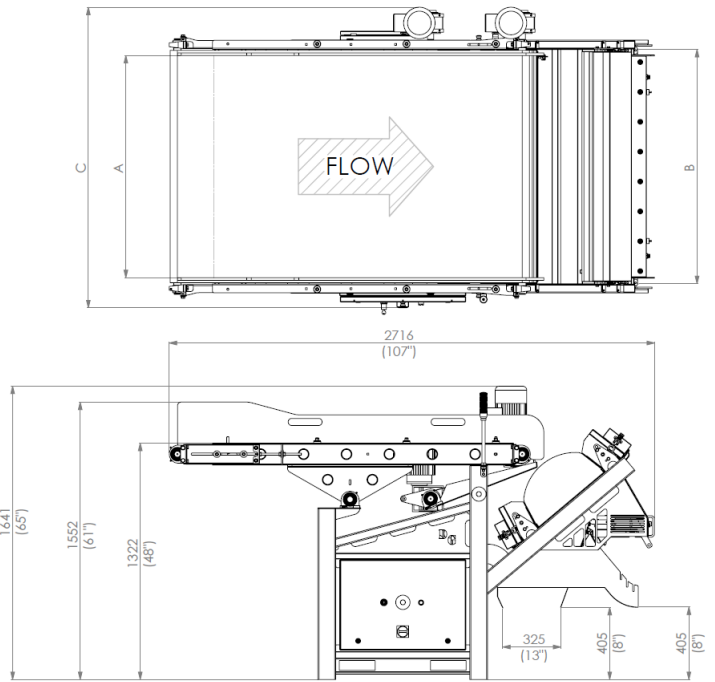

Version	A	B	C	Capacity
32"	760 - 30"	910 - 36"	1280 - 50"	35 Ton/h
40"	960 - 38"	1110 - 44"	1480 - 58"	45 Ton/h
48"	1160 - 46"	1310 - 52"	1680 - 66"	55 Ton/h
72"	1780 - 70"	1910 - 75"	2480 - 98"	85 Ton/h



## Other Applications



Dinamica Generale S.p.A.  
 Via Mondadori 15, 46025 Poggio Rusco MN, Italia Tel.:  
 +39 0386 52134 Fax: +39 0386 51523  
[info@dinamicagenerale.com](mailto:info@dinamicagenerale.com)

